

Full load weight

Wight full load	26.2 metric ton
Front axle load	20.7 metric ton
Rear axle load	5.5 metric ton

Diesel engine

Brand	VOLVO PENTA
Model	TAD850 VE
Type	Water-cooled low pollution diesel engine
Rated power output	160 kw@2200rpm
Starting method	Electric starter
Exhaust purifier	Oxidate catalytic
Fuel consumption 50% load	16 L/hour



Drive line

Power converter	DANA C273
Power transmission	DANA R32420 (4 speed)
Drive axle (front)	DANA 16D2149 with POSI-TORQ limited spin differential
Drive axle (rear)	DANA 16D2149 oscillate
Total ratio	26.11 (5.286×4.94)
Tires	17.5-25 smooth surface cut-resistance pneumatic tires



Brakes

Service brake	
Method	Wheel side POSI-STOP spring brake
Charging valve	MICO 06-463-020
Footage valve	MICO 03-460-420
Parking brake & Emergency brake	
Method	Wheel side POSI-STOP spring brake, hydraulic reset controlled with button inside the driver's cab With solenoid braking valve

Steering system

Type	All hydraulic pilot control power steering system
Steering pump	Parker high pressure oil pump
Steering angle (L+R)	42°

Liquid fill-in

Transmission	35 liter 6# or 8# hydraulic drive oil
Hydraulic oil tank	330 liter 68# wear resistance hydraulic oil
Drive axle	
Main drive	14 liters
Wheel side reducer	4 liters
Lubricant	GL-4 85W/90 heavy-load gear oil
Diesel	200 liters 0#

Options

- ✓ Automatic lubricate system
- ✓ Engine apartment fire suppression system
- ✓ Travel aid system
- ✓ Record and monitoring system
- ✓ Port for remote control for the whole vehicle
- ✓ Sealed cabin with air-conditioner (FOPs+ROPs and GB/T5143 standard)

EXTERNAL DIMENSIONS

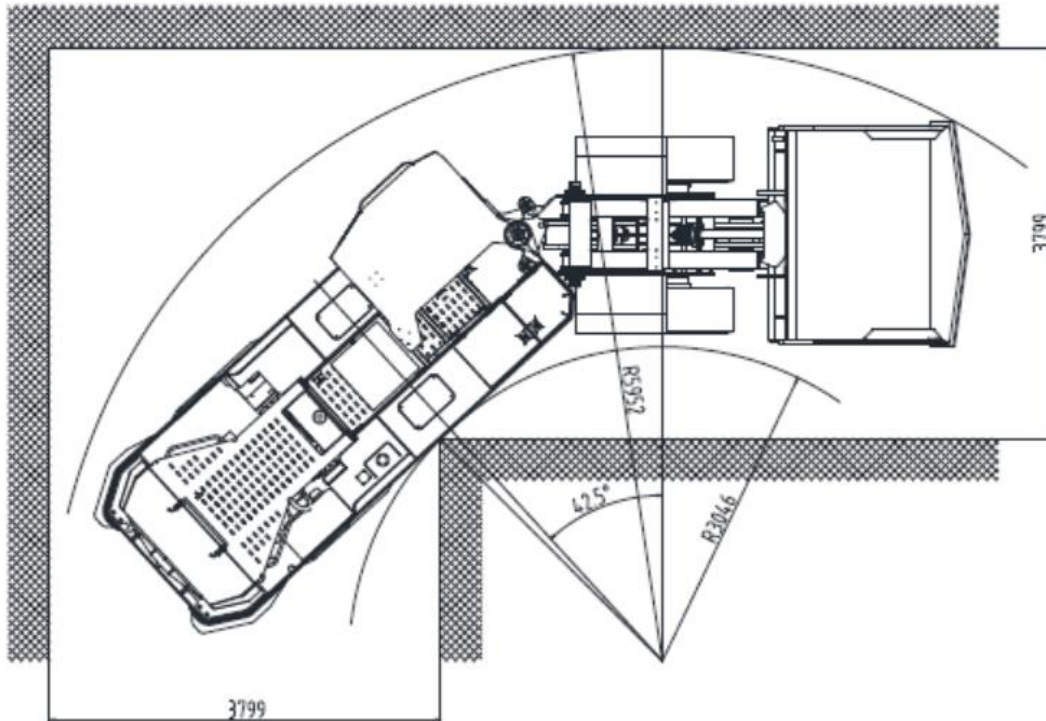
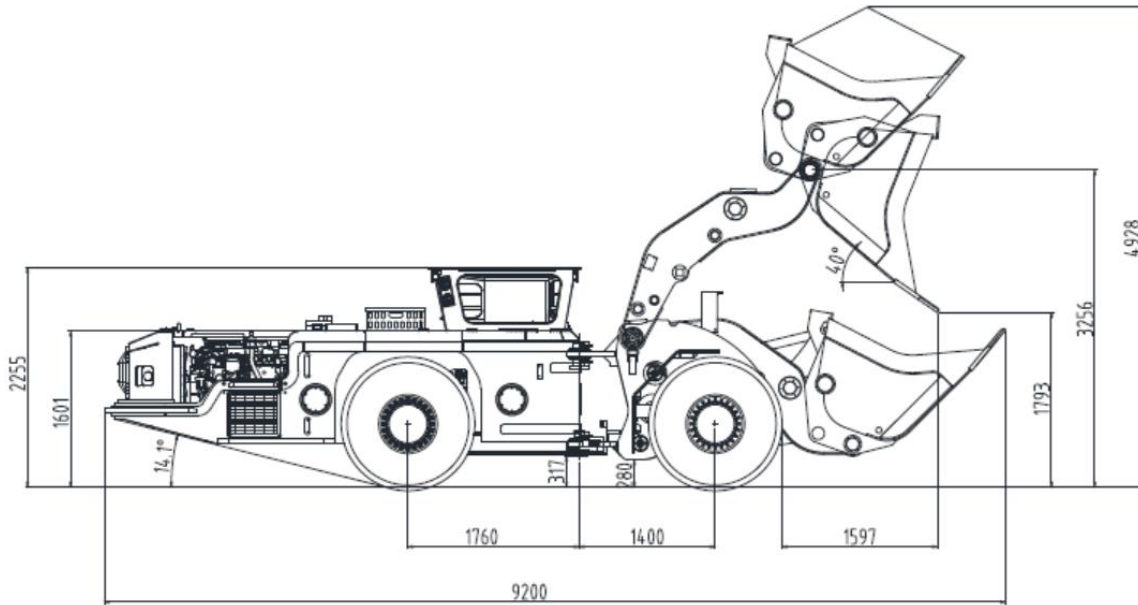

Consumables for WJ-3 Production Loader

S/N	Parts Name	Parts Number	Unit	Quantity
1	Bolts-transfer shaft	3/8-24UNF×50	pc	9
2	Bolts-transfer shaft	1/2-20UNF×65	pc	9
3	Bolts-transfer shaft	1/2-20UNF×60	pc	9
4	Bolts-transfer shaft	1/2-20UNF×70	pc	9
5	Repair kit-steering cylinder	HSGK01-100/50	pc	2
6	Repair kit-hoist cylinder	HSGK01-160/90	pc	2
7	Repair kit-tilting cylinder	HSGK01-200/110	pc	1
8	Filter element-travelling hydraulic	P165569	pc	2
9	Primary filter cartridge-diesel	R90P	pc	9
10	Fine filter cartridge-diesel	0118 2673	pc	9
11	Air filter element	EF5-65	pc	9
12	Filter element-oil suction	WU-630X100F-Y	pc	9
13	Filter element-return oil	WY-600X20	pc	9
14	Filter element-return oil	FBX-63X20	pc	9
15	Filter element-hydraulic oil	LH0060D010BN3HC	pc	5
16	Belt-engine fan		pc	1
17	Belt-generator		pc	1
18	Cardan	5C	pc	2
19	Cardan	7C	pc	4
20	Front fixed transfer shaft	7C840+20Z7C	pc	1
21	Middle transfer shaft	7C295+307C	pc	1
22	Transition transfer shaft	7C425Z7C	pc	1
23	Rear transfer shaft	7C345+357C	pc	1
24	Main transfer shaft	5C1140+505C	pc	1

KAMACH reserves the right to modify above specifications due to detailed customer need per delivery.

DETAILED PICTURES FOR REFERENCE:



NANCHANG KAMACH MINING CO., LTD.

Email: kamach@kamach.com Mobile: +86 13907098609 Website: www.kamach.co.uk
Address: C202, #948 Torch Avenue, Nanchang, 330096, China

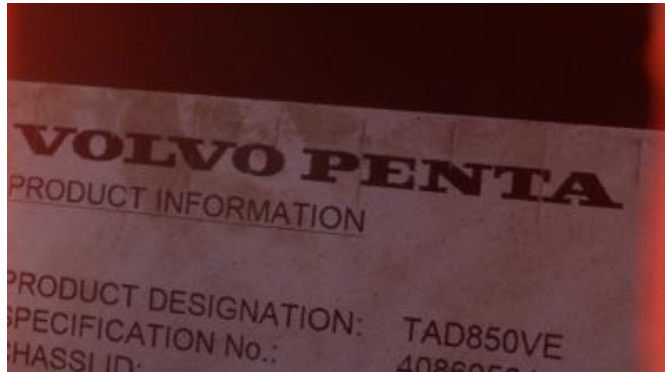

NANCHANG KAMACH MINING CO., LTD.

Email: kamach@kamach.com Mobile: +86 13907098609 Website: www.kamach.co.uk
Address: C202, #948 Torch Avenue, Nanchang, 330096, China