

## Small-sized Crawler Mucking Loader

LWL-60/30L  
(ZWY-60/30L)



LWL-60 crawler mucking loader is a continuous excavating, drawing, loading and feeding equipment for material transportation. It is mainly been used in tunnel construction, diversion culvert, cave construction, etc.

LWL-60 is suitable for tunnel section above 2.0×2.0, rock size≤495 mm. The mucking loader shovel rocks thru dig arm, then load them to the conveyor trough, transport the rocks thru scraper to the rear, and off load rocks to MineTruck, dumper, shuttle car, or other transporting vehicles. The mucking loader may also be used to scale the forefield.

LWL-60 mainly uses electric motor for crawling, use 3 phase electricity power for working;

The working mechanism include bucket, arm, boom, and rocker;

Crawling mechanism adopts hydraulic driving system, it is compact in structure, mobile for all terrain working conditions, and high grade-ability;

Pilot valve controlling, easy to operate, and to give maintenance.

FOPs+ROPs standard cabin, convenient for the driver to operate the mucking loader.

Your Ideal Mining Solutions for Underground Mining, Tunneling, Shaft sinking from China!

Main dimensions:		
Crawler ground contact length		2110 mm
Crawler inner width		700 mm
Track plate width:		300 mm
Transport trough inner width		495 mm
Dimensions during transport	Length	6650±50 mm
	Width	1600±50 mm
	Height	1780±50 mm
Dimensions during operation	Length	7850±50 mm
	Width	3100±50 mm
	Height	2350±50 mm

Working range	
Excavating width	3100 mm
Excavating distance (from feeder)	1780 mm
Excavating height	2350 mm
Excavating depth below ground level	518 mm
Dumping height	1375 mm
Minimum dumping height	1350 mm
Dumping distance	1400 mm
Maximum boom swinging angle	±55°
Adaptable tunnel size (Width×Height)	≥2m×2m

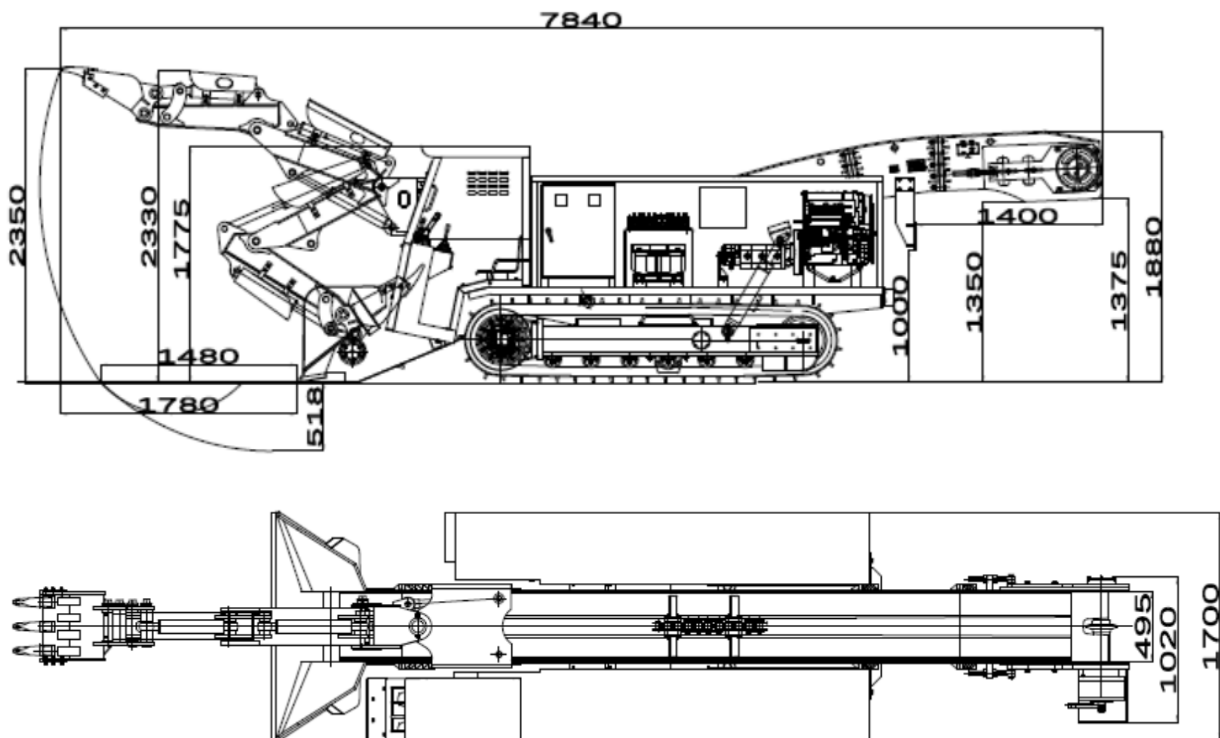

Your Ideal Mining Solutions for Underground Mining, Tunneling, Shaft sinking from China!

Functional Parameter	
Loading capacity	60m <sup>3</sup> /h
Electric motor power installed	30 kw
Working voltage	1140(660)V 50(60)Hz   660(380)V 50(60)Hz
Cooling method	Air-cooled
Travel speed	0.25±0.05 m/s
Scraper chain	Single chain single motor
Speed of scraper chain	34 m/min
Grade ability	≤30°
Minimum turning radius	≥4 m
Ground contact pressure	≤0.1 MPa
Steering method	Hydraulic
Volume of Hydraulic tank	200 L
Rated working pressure	20 Mpa
Hydraulic pump	Plunger pump ×2 + gear pump ×2
Walking hydraulic motor	Radial plunger motor ×2
Transport hydraulic motor	Radial plunger motor ×1

## ❖ AFTER-SALE SERVICE

Maximize productivity time and reduce costs for the clients.

- ✓ 1 year | 2000 engine hours warranty after commissioning;
- ✓ Rolling spare parts stock in the owner's country at supplier's cost;
- ✓ Free training in supplier's workshop;
- ✓ Free on-line training for the buyer's operators;
- ✓ 24-hours on-line support.

## ❖ Delivery reference:



Your Ideal Mining Solutions for Underground Mining, Tunneling, Shaft sinking from China!

