

UK-20 LP DUMP TRUCK

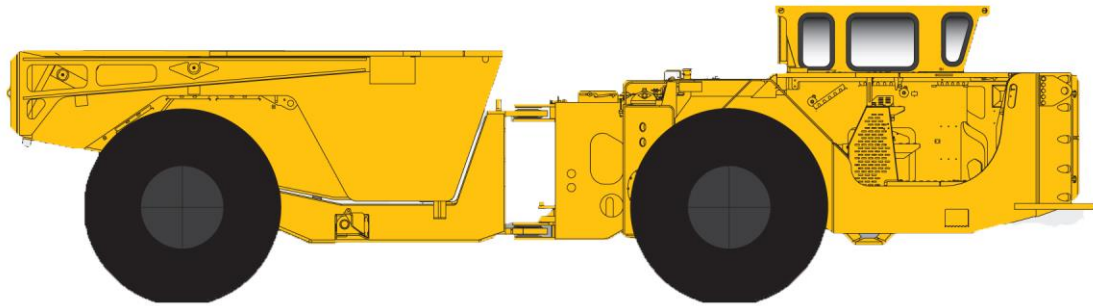

Weight

Without load	19500 kg
Fully load	39500 kg

Carriage

Max. Carrying capacity:	20000 kg
Volume (SAE heap):	10 m ³
Volume (SAE Flat) :	9 m ³

Service time

Carriage lifting:	15 s
Carriage descent:	11 s
Steering:	6 s

Engine

Manufacturer: Germany DEUTZ water-cooled diesel engine, central cooling, turbo-charged.

Model: BF6M1013FC ECM EURO 3 emission standard

Power: 223 kW /2200 rpm

Torque output: 1050 Nm /1700 rpm

Air-inlet: USA Donnalson air filter

Exhaust: Canada imported catalyst purifier+ silencer

Options:

Sweden VOLVO water-cooled diesel engine

Transmission:

Converter: DANA C5502
Transmission: DANA R36424
Advance, Reverse, 4 gears
Drive axle: DANA 19D2748

Brakes:

Service brake/ Parking brake: Spring brake hydraulic release, external cooling system, conbinated

Tyres: 18.00-25 /E-3 TT

Hydraulic system:

Main pump: PB5100	63.3 ml/r	PERMCO hydraulics
Control valve: SD180	160 L/min	Italy Walvoil

Electric control pilot joystick

Hydraulic cylinder:	HSGK01-140	Multistage, Changjiang
Braking pump:	P124A	15.2 ml/r Permco hydraulics
Charging valve:	06-463 USA	MICO
Brake valve :	03-460 USA	MICO
Radiator pump:	with diesel engine	
Radiator motor:	Permco hydraulics	

Steering

Type: All hydraulic power steering system, central articulation, dual cylinder steering frame.

Steering cylinder model: HSGK01-125/70E

Steering radius: Inner 4700 mm External 7700 mm

Steering angle: 42°

Vehicle speed (km/h):

1 st gear	6.1
2 nd gear	11
3 rd gear	19
4 th gear	31

Grade ability : 4.5km/h at 25% slope fully load

Electric system

Voltage: 24V

Generator: BOSCH 28V/35A

Starter motor: BOSCH 3.6KW/24V

Battery: 2×12V /165Ah

Illumination: Front/Rear lamp/Reverse×2, Roof lamp×2

Fire suppression

Type: Manual fire extinguisher

Instrument:

Ammeter/Hourmeter/Preheating indicator/Engine thermometer/Engine coolant thermometer/Transmission thermometer/engine hydraulic pressure gauge/hydraulic brake pressure gauge/brake system low pressure warning/engine water temperature warning/diesel engine low hydraulic pressure warning/diesel level gauge/carriage lifting warning.

Cabin

Front-view seat, sealed cabin

SAE standard ROPS/ROPS cabin

Lubrication

Central lubrication

OPTIONS:

1. Volvo Water-cooled diesel engine
2. Automatic central lubrication
3. Automatic and manual fire suppression system
4. Audio & Video system for monitoring the operation
5. Sealed cabin with air-conditioner and heater

