

## UK-12 MineTruck

UK-12 MineTruck is used together with 3~7 ton loading capacity loaders to take the minerals to the pit.

**Main features:**

1. Front-view seat or side-view seat
2. Deutz engine with turbo Charger
3. DANA transmission and converter
4. Main hydraulic components from Parker,Permco,MICO,Williams,etc.

Rated Loading Capacity	
Stowage loading	6 m3
Flat loading:	5 m3
Rated loading capacity by weight	12 Metric Ton
Maximum grade ability	25% (14°)
Maximum traction force	130 KN

Weight	
Empty weight	12.7 Metric Ton
Complete weight	24.7 Metric Ton

Dimensions	
Length	7,615 mm
Width	1,900 mm
Height to cabin	2,050 mm
Wagon box off-load height	4,000 mm
Wagon box off-load angle	70°
Wagon box approach angle	16.4°
Departure angle	38.6°
Steering angle	±40°
Front axle oscillate angle	±8°
Ground clearance	310 mm

Turning Radius	
External	6,520mm
Inner	4,030mm

Time	
Wagon box lifting	13 sec
Wagon box descend	10 sec

Travelling speed (F/R)	
1 <sup>ST</sup> Gear	5.5 km/h
2 <sup>nd</sup> Gear	11 km/h
3 <sup>rd</sup> Gear	21 km/h
4 <sup>th</sup> Gear	28 km/h

PowerTrain	
Engine brand	DEUTZ
Model	TCD914 air-cooled low pollution diesel engine with turbo-charges
Rated power/rpm	130 kW@2300 r/min
Starting method	Electric starter
Exhaust purifier	DOC+POC+Silencer
Throttle controller	Williams accelerator

Driveline	
Transmission type	Hydraulic + manual
Transmission	DANA R32000 series
Converter	DANA C273.7
Drive axle	Meritor CY-2JD/E-C
Tire size	14.00 R24

Braking system	
Braking pump	PERMCO PB5100
Travelling brake	POSI-STOP wet multiple discs brake, Spring pressured braked, hydraulic release
Braking valve	MICO 03-460-404
Charging valve	MICO 06-643-020
Parking brake & Emergency brake	POSI-STOP wet multiple discs brake, Spring pressured brake, hydraulic release; When transmission oil level too low, when engine shut-down, the truck will be automatically braked

Steering system	
Type	Fully hydraulic power steering, central articulation
Steering pump	Permco PB5100
Steering device	EATON BZZ-800
Priority valve	EATON VLE-150
Steering cylinder housing DIA/rod DIA×Quantity	Φ100 mm/Φ55 mm×2

Operation system	
Wagon box lifting valve	WALVOIL SD14
Lifting cylinder housing DIA/rod DIA×Quantity	Φ100 mm/Φ55 mm×2

Electrical system	
System Voltage	24V DC
Starting motor Voltage/Power	24V DC/4 KW
Lighting	Front LED Light 18W/24V×2
	Rear LED Light 18W/24V×2
	Mining flame-proof blinker 24V×1

Driver's cabin	
America SAE standard Cabin (ROPS/FOPS)	
Seat with suspension and safety belt	

Liquid fill-in	
Fuel tank volume	180 Liter
Hydraulic oil tank volume	120 Liter

Dis-assembly size and weight		
Front chassis	4042 mm×1840 mm×1592 mm	3500 kg
Rear chassis	3144 mm×1534 mm× 840 mm	1500 kg
Wagon box	3710 mm×1900 mm×1308 mm	2600 kg

## Spare parts with delivery

S/N	Parts name	Parts code	Assembly	Unit (ea)	Qty	Remark/set
1	Air filter element (outer)	P812160	Engine	ea	12	Replace 1 ea/1 month
2	Air filter element (inner)	P836245	Engine	ea	6	Replace 1 ea/2 month
3	Air filter element-Fuel tank	QUQ2-20×1	Engine	ea	1	Fuel inlet
4	Filter element -Travelling hydraulic	8602B09	Converter	ea	2	Replace 1 ea/6 month
5	Filter element -engine lub. Oil		Engine	ea	12	Replace 1 ea/2 month
6	Filter element -Fuel		Engine	ea	6	Replace 1 ea/2 month
7	Hydraulic oil filter-return	GP-A400	Hydraulic	ea	4	Replace 1 ea/3 month
8	Hydraulic oil filter-suction	WU-4×100F-J	Hydraulic	ea	4	Replace 1 ea/3 month
9	Oil filter	PLF-H110×10P	Hydraulic	ea	4	Replace 1 ea/3 month
10	Hydraulic oil level indicator	860401B03	Hydraulic	ea	1	Back-up
11	Repair kit-steering cylinder	100/55	Steering	set	2	Back-up
12	Repair kit-Lifting cylinder	125/90	Operation	set	2	Back-up
13	Joint bearing		Steering	ea	2	Steering cylinder
14	Joint bearing		Operation	ea	2	Lifting cylinder
15	Joint bearing	8609B01	Driveline	ea	2	Articulation
16	Bolts-transfer shaft	3/8-24UNF*50	Driveline	ea	20	Transfer shaft
17	Bolts-transfer shaft	1/2-20UNF*60	Driveline	ea	20	Transfer shaft
18	Bolts-transfer shaft	1/2-20UNF*65	Driveline	ea	20	Transfer shaft
19	Bolts-transfer shaft	M12*1.25*50	Driveline	ea	20	Transfer shaft
20	Cardan shaft	5C	Driveline	ea	4	Back-up
21	Cardan shaft	7C	Driveline	ea	8	Back-up
22	Tire with rim	14.00-24	Driveline	ea	1	Back-up
23	Engine belt		Engine	ea	1	Back-up
24	Generator belt		Engine	ea	1	Back-up
25	Copper sleeve (Up+Down)		Articulation	set	2	Back-up 2 sets/truck
26	Y+O seal		Axle	set	2	Axle
27	Floating seal		Axle	set	2	Axle
28	Steering device		Steering	set	1	
29	Throttle controller		Driveline	set	1	
30	Operator's manual			set	1	
31	Parts catalogue			set	1	

## External Dimensions

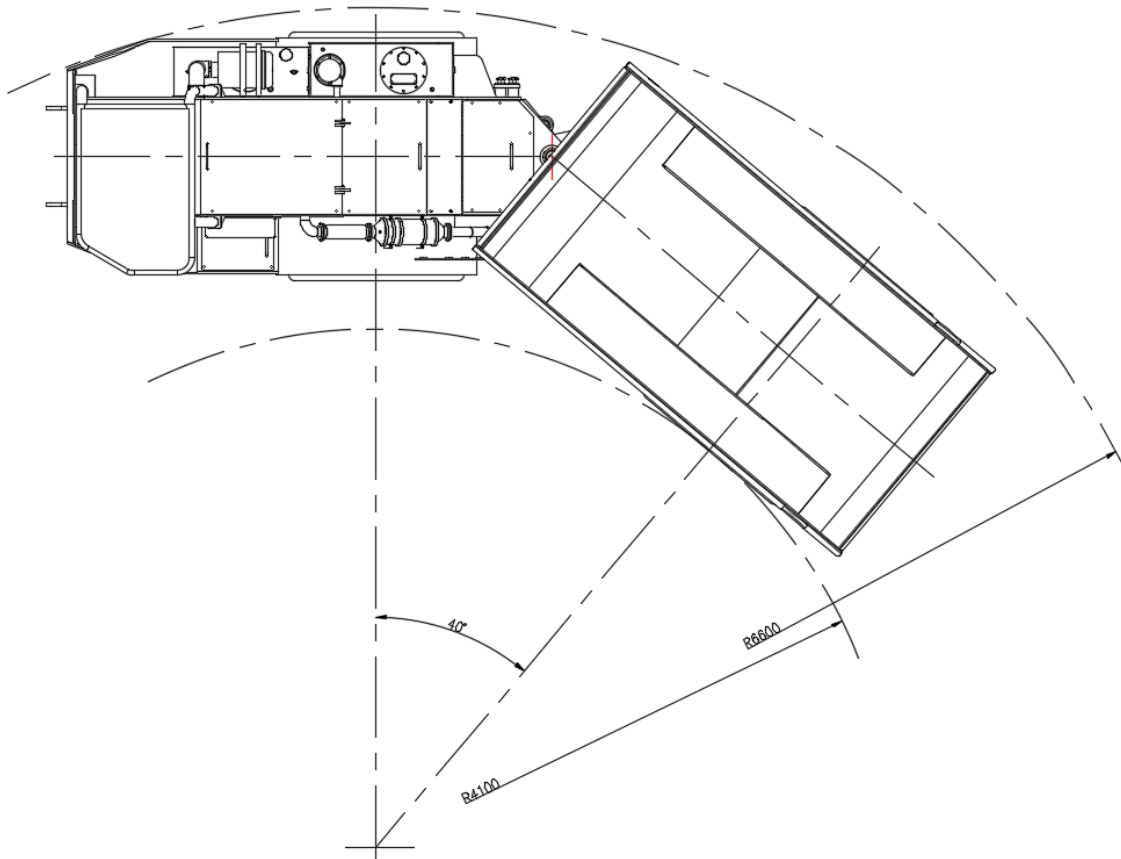
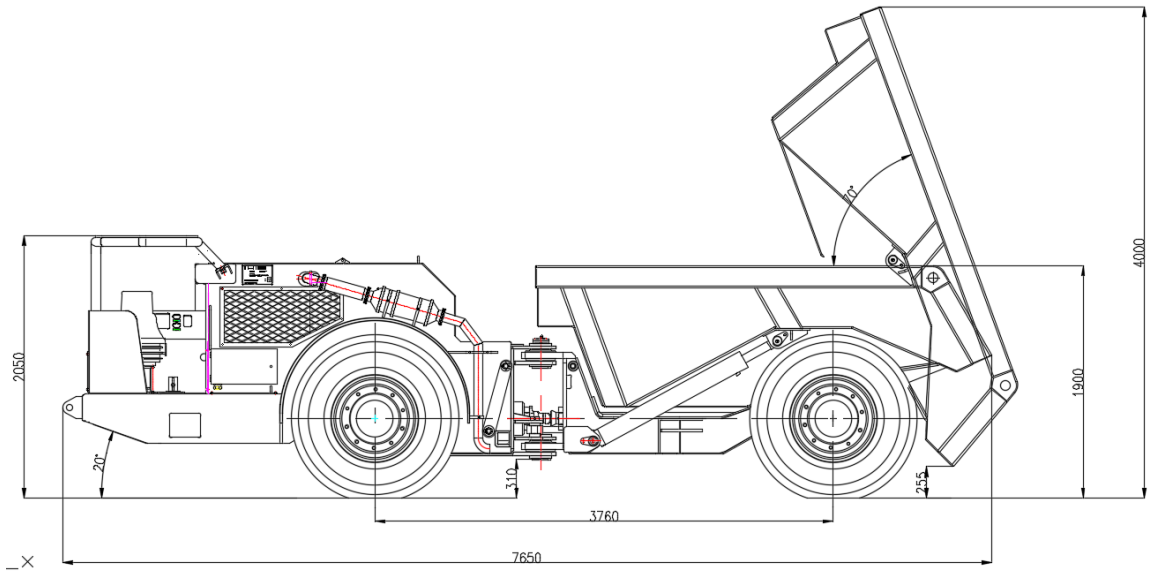









## Services:

- ✓ Warranty: 1 year | 2000 engine hours with free material and freight
- ✓ Parts stock for 1 year application with delivery of the truck;
- ✓ Urgent parts sent by DHL at **KAMACH** cost.
- ✓ On-line 24 hours services
- ✓ Service Hotline:

Latin America: + (57) 3173635352 | +(57) 3053562629 | +57(604) 3570526  
China: +(86) 13907098609 | +(86) 791 8761 5235